

The PD Phylogenetic Diversity Framework: Linking Evolutionary History to Feature Diversity for Biodiversity Conservation

Daniel P. Faith

Abstract Feature diversity refers to the relative number of different features represented among species or other taxa. As a storehouse of possible future benefits to people, it is an important focus for biodiversity conservation. The PD phylogenetic diversity measure provides a way to measure biodiversity at the level of features. PD assumes an evolutionary model in which shared features are explained by shared ancestry. This avoids philosophical and practical weaknesses of the conventional interpretation of biodiversity as based on some measure of pair-wise differences among taxa. The link to features also provides a family of PD-based calculations that can be interpreted as if we are counting-up features of taxa. The range of feature diversity calculations assists comparisons of methods, and helps overcome the current lack of review and synthesis of the variety of proposed methods for integrating evolutionary history into biodiversity conservation. One family of popular indices is based on the evolutionary distinctiveness (ED) measure. These indices all have the limitation that complementarity, reflecting degree of phylogenetic overlap among taxa, is not properly taken into account. Related indices provide priorities or other scores for geographic areas, but do not effectively combine complementarity, probabilities of extinction, and measures of restricted-range. PD-based measures can overcome these problems. Applications include the identification of key biodiversity sites of global significance for biodiversity conservation.

Keywords Option value • Endemism • IPBES • Philosophy of science • IUCN

Introduction

This book addresses important concepts, methods, and applications related to the increasingly important role of evolutionary history in biodiversity conservation. The preservation of the rich heritage represented by the evolutionary history of taxa is a

D.P. Faith (✉)

AMRI, The Australian Museum, Sydney, NSW 2010, Australia

e-mail: dan.fait@austrmus.gov.au

© The Author(s) 2016

R. Pellens, P. Grandcolas (eds.), *Biodiversity Conservation and Phylogenetic*

Systematics, Topics in Biodiversity and Conservation 14,

DOI 10.1007/978-3-319-22461-9_3

natural conservation goal (e.g. Mooers and Atkins 2003). This fundamental relationship between evolutionary history and conservation goals traces back at least to the IUCN (1980) proposal that taxonomically distinctive species may deserve greater conservation priority. At about the same time, Soulé (1980), in his book, *Conservation biology: an evolutionary-ecological perspective*, articulated a broad evolutionary perspective for conservation, and argued that “reduction of the biological diversity of the planet is the most basic issue of our time.”

The term “phylogenetic diversity” is relevant to these biodiversity conservation perspectives. The term can be traced back to the introduction of the “PD” phylogenetic diversity index (Faith 1992a, b, 1994a). PD was designed as a simple measure of the degree of representation of evolutionary history (by a given set of taxa). Faith (2002) summarised the basic definition and rationale for PD: “representation of “evolutionary history” (Faith 1994b) encompassing processes of cladogenesis and anagenesis is assumed to provide representation of the feature diversity of organisms. Specifically, the phylogenetic diversity (PD) measure estimates the relative feature diversity of any nominated set of species by the sum of the lengths of all those phylogenetic branches spanned by the set.”

That summary mentions species, but Faith (1992a, b) in fact applied PD from the outset not only to phylogenies whose tips were species, but also to phylogenetic pattern among genetic haplotypes or populations, in order to set spatial priorities to conserve within species genetic diversity (see also Faith et al. 2009). The common element across these levels is the inference of underlying diversity, where the units of variation are features or traits of taxa. This link to “features” reflects the attempt, through PD calculations, to address a fundamental concern of biodiversity conservation - unknown variation, with unknown future values. Faith (1992a, b) suggested that the interpretation of phylogenetic diversity as a measure of feature diversity helps to clarify its link to conservation values: “Diversity is seen as important as the raw material for adapting to change (McNeely et al. 1990), and so provides what McNeely et al. (1990) and others call ‘option value’: a safety net of biological diversity for responding to unpredictable events or needs. The diversity of features represented by a subset of species provides option value in ensuring not only that one or more members of the subset can adapt to changing conditions, but also that society may be able to benefit (e.g. economically) from features of these species in response to future needs.”

Examples of these benefits include many from bioprospecting. For example, Smith and Wheeler (2006) have used phylogeny to assess potential for new discoveries of piscine venoms. Pacharawongsakda et al. (2009) have applied PD to help find natural products from microbes. Another interesting example is found in the study of Saslis-Lagoudakisa et al. (2012). Phylogenetically-related plants have provided a key medical component, discovered independently in the plants found in three different regions.

This perspective accords well with the IUCN (1980) argument for conservation of diversity in order to ensure benefits “for present and future use”. Reid and Miller (1989) echoed these ideas in their early paper, “Keeping options alive: the scientific basis for conserving biodiversity” (see also Wilson 1992; McNeely 1988; Faith 1992a, b). The Millennium Ecosystem Assessment (MA 2005) summarised this

general link between biodiversity and option values: “Biodiversity loss is important in its own right because biodiversity has cultural values, because many people ascribe intrinsic value to biodiversity, and because it represents unexplored options for the future (option values)”.

Option value therefore reflects not only the unknown future benefits from known elements of biodiversity, but also the unknown benefits from unknown elements. The Millennium Ecosystem Assessment (2005) also called for “a ‘calculus’ of biodiversity, so that gains and losses at the level of biodiversity option values can be quantified”. These ideas are echoed in the conceptual framework for the Intergovernmental Science-Policy Platform on Biodiversity and Ecosystem Services (IPBES; UNEP 2013) which says that values “include bequest value – in other words, the preservation of nature for future generations – or the option values of biodiversity as a reservoir of yet-to-be discovered uses from known and still unknown species and biological processes, or as a constant source, through evolutionary processes, of novel biological solutions to the challenges of a changing environment.”

The PD measure is an attempt to make inferences about “features” as units of variation, including features that are not yet known to science. Faith (1994a, b) characterised PD as one case of a general framework for biodiversity assessment that uses pattern-process models to link objects and lower-level units. In general, the biodiversity units are the things we would like to count up, and the objects contain various units. Typically, many units remain unobserved/unknown, and a pattern-process model defines relationships among the objects, enabling inference of the relative numbers of units represented by different sets of objects (Faith 1994a, b). Thus, PD provides the specific case where species (or haplotypes or populations) are the objects, features are the units, and the pattern-process inferential model is based on evolutionary processes of cladogenesis and anagenesis, manifested in phylogenetic pattern.

The link from phylogeny to feature diversity has supported the wide application of PD. For example, Huang et al. (2012) advocated the use of PD in conservation based on their finding that it provides a much stronger link to “trait diversity”, relative to species. Jono and Pavoine’s (2012) study of threat diversity as a determinant of the extinction risk in mammals assessed the consequences of species declines used PD with the rationale that it “is becoming a key criterion in conservation studies because it can reflect the variety of unique or rare features of a species.”

This rationale has extended to application of PD within ecosystems, where the conservation/management goals focus on maintaining ecosystem functions and services. For example, Cadotte and Davies (2010) argued that “maximizing the preservation of PD will also tend to maximize the preservation of feature diversity, including unmeasured, but ecologically important traits” (see also Gravel et al. 2012).

Studies also link PD, feature diversity, and option values. For example, Larsen et al. (2012) argued that “it is difficult to provide a robust proxy for ‘option value’ – the potential value to society – as these values are not yet realized”, and concluded that “a compelling argument can be made that maximizing the retention of phylogenetic diversity (PD) should also maximize option value, as well as diversification and adaptation of the species in a future of climatic change”. The influential study of Forest et al. (2007) also highlighted the importance of PD as a link to feature

diversity. They explored PD and option value based on an estimated phylogenetic tree and the geographic distribution of angiosperm genera found in the Cape hotspot of South Africa. Forest et al. (2007) concluded that, if we did not know about the medicinal, food, and other useful features of these plants, then preserving sets of species with high PD would be a good way to preserve these unknown features and their associated benefits.

PD now is regarded as “a leading measure in quantifying the biodiversity of a collection of species” (Bordewich and Sempel 2012) and as “a resonant symbol of the current biodiversity crisis” (Davies and Buckley 2011), with important applications at both regional/global (e.g. Forest et al. 2007) and within-ecosystem scales (e.g. Cadotte et al. 2009). At the same time, PD must be acknowledged as just one of many biodiversity measures that are based on aspects of evolutionary history (see other chapters in this book). Unfortunately, there is no existing comprehensive review and synthesis covering all these measures. For example, Diniz Filho et al. (2013) recently concluded that “we do not even have a comprehensive and integrative approach to using phylogenies in biodiversity conservation.” Similarly, a recent review of past studies on the topic of evolutionary history and conservation (Winter et al. 2013) argued that there is little basis for distinguishing among the large number of existing phylogenetic indices (see also Devictor et al. 2010).

Partly, the existence of a gap in review and synthesis is not surprising; this area of research is evolving rapidly. The PD measure is applied in various sub-disciplines, highlighting distinctions between within-ecosystem versus global scales, microbial versus macrobial, and taxonomic levels ranging from populations to species and higher taxa (e.g., May-Collado and Agnarsson 2011; Lozupone and Knight 2005; Jono and Pavoine 2012; Jetz et al. 2014).

The other obstacle to synthesis is that, while some attempts at review and synthesis have been made, most have been incomplete or unsuccessful. Notably, philosophers of science have become keenly interested in the science of phylogeny and biodiversity conservation, but have not yet shed much light on the problem (for discussion, see Faith 2013). Philosophers so far largely have focussed on one possible unifying conceptual model of biodiversity. This model traces back to Weitzman’s (1992) general framework for biodiversity, based on the idea of objects, and measures of difference between pairs of objects. The biodiversity of a given set of objects then is reflected, not in a list of the different objects, but in the amount of difference represented by the set. Weikard (2002), following Weitzman’s object-differences framework, argued that “an operational concept of diversity must rely on some measure of dissimilarity between appropriately defined objects.” Maclaurin and Sterelny (2008), in their book, “What is biodiversity?”, and Morgan (2010) also saw this approach as a core framework for characterising biodiversity (the Lean and Maclaurin chapter “The Value of Phylogenetic Diversity”, also takes this as their starting point).

This approach assumes that we can decide on the definition of meaningful differences among the initial objects, and most authors have acknowledged that it is hard to choose among many possible notions of difference. This has not helped in developing a synthesis for phylogenetic measures of diversity. Winter et al. (2013) incor-

rectly interpreted “phylogenetic diversity” as any measure derived from a nominated between-species phylogenetic distance. Their conclusion, that there is little basis for distinguishing among different phylogenetic indices, highlighted well the problems in choosing among different notions of differences. Unfortunately, Winter et al. did not recognize PD as distinctive in avoiding arbitrary notions of difference, and instead using a model-based measure of feature diversity and option values.

A more recent study, by Kelly et al. (2014), acknowledged the feature diversity interpretation of PD, but surprisingly failed to acknowledge its pattern-process model, in which shared ancestry explains shared features. An implication of that model, emphasised from the outset, was that PD will fail to account for convergently-derived features, and that these may be captured by an alternative pattern process model (see Faith 1992a, b, 1996, 2015). The failure to recognise these key lessons from the early work left Kelly et al. destined to merely re-discover the already well-established point that convergences will not be accounted for by PD, rather than making any real progress towards evaluation and synthesis (and perhaps exploring the alternative pattern-process model).

Lack of comparisons and synthesis has made it difficult to interpret some otherwise useful studies. This problem is well illustrated in the recent study by Pio et al. (2014), where “PD” is used to refer to any diversity measure linked in any way to phylogeny. They refer to a variety of published studies on the performance of “PD”, but the reader cannot know when this refers to true PD and when it refers to some other measure. Pio et al. go on to apply the actual PD method in their analyses, but without reference to that as the Faith (1992a) PD method.

Beyond the confusion in terms, there remains a genuine need to compare methods and develop synthesis. The pattern-process model approach that is the basis for PD can help in two ways. First, we can use the PD family of calculations to better recognise that there are many inter-linked, related, indices (dissimilarity, endemism, etc) rather than lots of indices that can be called “diversity” measures (for related discussion, see Sarkar 2008). In the next section, I briefly consider the PD’s counting-up of features as one way to integrate other possible calculations that can be based on those counts. I then turn to the second way that PD’s pattern-process model can help. Here, I will evaluate alternative measures, including those outside PD framework, by examining how well they can be interpreted under the PD features model.

Calculations and Comparisons

Simple Calculations Based on PD

Many possible calculations can be based on counting-up features within the PD framework. As examples, complementarity, endemism, and dissimilarities between objects all can be calculated. In principle, every index conventionally defined in ecology at the species level has its counterpart for other biodiversity units. Counting-up the total number of features (as units) represented by a set of taxa

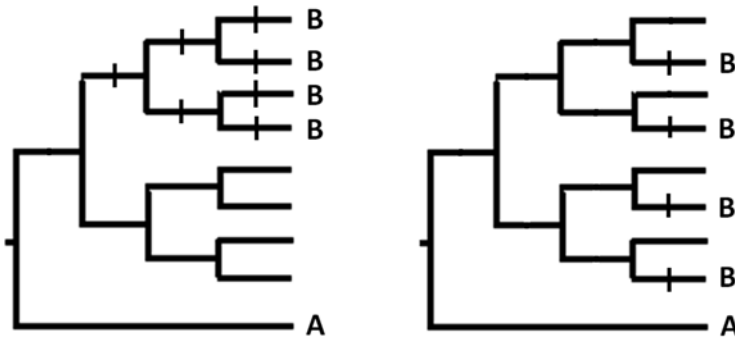

Fig. 1 For each tree, the tick marks correspond to loss in PD if each species from area B is lost. The *tick marks* show how much PD is uniquely represented by that area. PD endemism sees the scenario on the left as implying greater endemism of area B, compared to the scenario on the right. The W_e method cannot distinguish between the two scenarios because it ignores a critical aspect of phylogenetic context, called complementarity

remains the core measure of “diversity”, but the other calculations capture other aspects – for example, expected change in biodiversity as a result of extinction.

Useful PD calculations for biodiversity comparisons among geographic localities include PD-dissimilarities between places or samples (see Lozupone and Knight 2005) and PD-endemism (Faith et al. 2004; illustrated in Fig. 1). Another useful calculation is “expected PD”, based on estimated probabilities of extinction. Here, species’ estimated extinction probabilities indicate amounts of “expected PD loss” (discussed further below; see also Faith 2008, 2013). All these calculations operate as if we are applying the standard species-based measures at the features level. Thus, these newer calculations make sense, given the interpretation of PD as counting-up features.

This interpretation has helped to justify other recent proposed extensions of PD. One important case is the integration of abundance information. Faith and Richards (2012) noted that a PD-based Hill numbers framework (Chao et al. 2010; see also Chao et al. chapter “[Phylogenetic Diversity Measures and Their Decomposition: A Framework Based on Hill Numbers](#)”) can be interpreted as an application of the standard species-level Hill numbers calculation, but with evolutionary features (as indicated by PD) substituted for species. Thus, the basic PD evolutionary model provides a simple justification for a phylogenetic measure integrating abundance information.

Complementarity: A Key PD Attribute

Interpretation of PD as counting-up features extends the fundamental species-level measure of “complementarity” to the features level. A taxon complements others in representing additional evolutionary history (Faith 1994a, b), as depicted in the

branches of the estimated phylogeny. The degree of complementarity reflects the relative number of additional features contributed by that species. For example, given some subset of species that are well-protected, and two species in that taxonomic group that are endangered, the priority for conservation investment may depend on the relative gains in feature diversity (the complementarity values) expected for each species.

Given the importance of complementarity, particularly when dealing with complex conservation issues, it is worth comparing PD with some published phylogenetic calculations. Calculating PD naturally requires that phylogenetic overlap among taxa be taken into account, so that branches – and corresponding features – are not multi-counted. Often, when PD is not applied correctly, the result is a misleading multiple-counting of features. For example, Perez-Losada et al. (2002) incorrectly calculated PD values for sets of freshwater crab species. They simply added up the PD values for individual taxa to produce the overall score for the set of taxa. Consequently, their measure, in multi-counting branches, did not correspond to a valid calculation of PD. Similarly, a study by Vamosi and Wilson (2008), using the term “EH” to refer to evolutionary history, stated that “the combined EH of all the angiosperm orders and families was estimated at 35,244 million years by summing the ages of the separate clades over the angiosperm phylogeny.” Their “combined EH” measure, in multi-counting branches, did not correspond to an estimate of PD. PD calculations would have better captured their intention to assess loss of traits/features.

Calculations Using Phylogenetic Distinctiveness Fail to Integrate Complementarity

More complex calculations have used measures of phylogenetic or taxonomic “distinctiveness”. These values, calculated for individual taxa, are then to be combined to score sets of taxa or areas. The problem for all popular variants of this approach – whether the terminal taxa (or tips for the tree) are individuals, populations, or places, is that the scores for the taxa do not add up to the proper scores for sets of taxa.

In an early example of such an approach (López-Osorio and Miranda-Esquivel 2010), an area received a score equal simply to the sum of individual scores of member species. López-Osorio and Miranda-Esquivel (2010) used 50 phylogenies covering multiple taxonomic groups in the Amazon, and integrated this phylogenetic information into conservation priority setting in order to “establish conservation priorities for Amazonia’s areas of endemism on the basis of measures of evolutionary distinctiveness”. “Taxonomic rarity” was to be indicated by species that are members of a small number of groups on the cladogram. López-Osorio and Miranda-Esquivel (2010) used an approach suggested by Posadas et al. (2001), which extends the W Index of Vane-Wright et al. (1991). The W index assigns to each species a value that is inversely related to the count of the number of groups on

the phylogenetic tree for which the species is a member. Thus, a species that is taxonomically (phylogenetically) distinctive will have a high W value reflecting its relatively few close relatives. The key index derived from W is the W_e index (each W value is divided by the number of areas with that species, yielding W_e). An area receives a score, equal to the sum of the W_e values of its species. This is to indicate a degree of endemism that integrates phylogeny.

Faith et al. (2004) compared those measures to the phylogenetic diversity measure, PD, and its associated calculations. Faith et al. argued that the W_e indices for areas differ from PD in not considering the degree of phylogenetic overlap/non-overlap among species (phylogenetic complementarity), and so may fail to effectively represent evolutionary history in priority sets of species or areas. A simple example of the problem is illustrated in Fig. 1. The W_e method cannot distinguish between the scenarios, yet the PD-endemism value differs for the two.

A family of relatively new measures, while based on PD, also does not fully account for complementarity. ED (“evolutionary distinctiveness”; Isaac et al. 2007; see also Collen et al. 2011) divides up the total PD among all species on the given phylogeny. This provides a fixed score for each species, reflecting its contribution to the total evolutionary history (PD). A species receives a partial credit for each ancestral branch. Thus, ED appears to capture the idea of complementarity among species. However, a key limitation is apparent when species ED scores are combined to provide scores for areas or for sets of priority species. Here, the ED approach does not take phylogenetic complementarity among the species into account. For example, consider the phylogenetic tree in Fig. 2. Based on summed ED scores, we cannot distinguish between an area with four closely related species and an area with four distantly related species; yet the scenario on the right corresponds to higher PD.

Such limitations may be critical in assessing diversity within communities or assemblages. In this context, phylogenetic diversity may be predictive of functionality or productivity (Cadotte et al. 2009). Dalerum (2013) set out to investigate the possible correspondence between phylogenetic diversity and functional diversity for assemblages of large carnivores. While Dalerum referred to “phylogenetic diversity” and to “PD”, in fact, their study used ED, not PD. Dalerum calculated ED for each species and then “estimated the ED of each assembly as the sum of the ED of contributing species.” As the simple example of Fig. 2 shows, this summed ED score will not correspond to the total PD. Unfortunately, the Dalerum study therefore provides little useful evidence for the claimed relationship between phylogenetic and functional diversity in assemblages of large terrestrial carnivores.

These same issues arise for regional or global studies. An interesting study by Daru et al. (2013) on mangroves “identified biogeographic regions that are relatively species-poor but rich in evolutionary history.” While the study presented results referring to loss of “mangrove phylogenetic diversity”, in fact, the measure used was based on ED calculations. Daru et al. argued for the significance of the finding that “areas with a high proportion of species experiencing global declines correspond to areas of unique evolutionary history” arguing that “the loss of currently threatened species might still have a disproportionate impact on mangrove

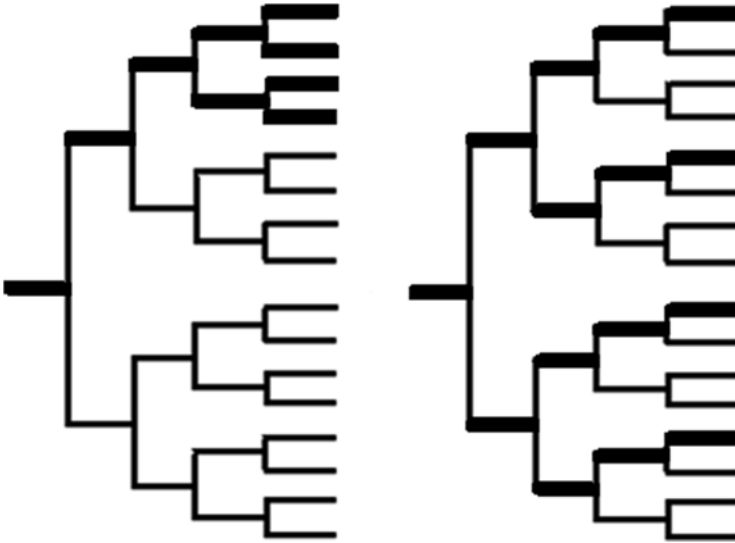

Fig. 2 Two drawings of a hypothetical phylogenetic tree. For this simple tree, the ED value is the same for every species. Given the unit length branches, it is $1 + \frac{1}{2} + \frac{1}{4} + \frac{1}{8} + \frac{1}{16} = 1.94$. Dark branches in each case indicate the PD represented by the species in an area. On the *left*, the area has four closely related species and on the *right*, the area has four distantly related species – and higher total PD. The PD on the *left* is 9 units, compared to a much higher PD of 15 on the *right*

phylogenetic diversity regionally”. This conclusion was based on apparent “overlap between regions in which species are undergoing declines and regions rich in evolutionarily distinct species.” Unfortunately, their use of a sum of species’ ED values as the regional indicator of phylogenetic diversity loss provides only weak evidence. To see this I again consider Fig. 1. For both trees, the sum of the ED values for the four species found in area B is the same. Thus, ED cannot distinguish between the large PD loss when the species are phylogenetically clumped, and the smaller PD loss when the species are phylogenetically dispersed (as in Fig. 1, left). Again, the PD loss corresponding to an area loss is not well-indicated by total ED, because phylogenetic complementarity is ignored.

A contrasting study is that of Abellán et al. (2013), who found that most of the highly evolutionarily distinct and vulnerable taxa were not covered by any national parks. Critically, while distinctiveness was noted, their proposed solution was based on priorities for areas providing increased PD. They concluded that “when additional conservation areas were selected maximizing the number of unrepresented species, the variation in PD could be very high, and as a consequence, depending on the group and the number of areas added, they could preserve much less evolutionary history than when they were specifically selected to maximize PD.”

The weakness of summed ED scores resembles the limitations of the López-Osorio and Miranda-Esquivel method. This kind of problem seems to link to a long-standing idea that we simply might add up scores for individual taxa, perhaps with

some distinctiveness “weighting”. For example, Gotelli and Chao (2013), in the *Encyclopedia of Biodiversity*, claim that we can calculate “PD” by appropriately weighting the species and then applying conventional species indices such as richness: “The concept of traditional diversity can therefore be extended to consider differences among species.... Differences among species can be based directly on their evolutionary histories, either in the form of taxonomic classification (referred to as taxonomic diversity) or phylogeny (referred to as phylogenetic diversity (PD)) ... weighting each species by a measure of its ...phylogeny.”

The relationship between ED and PD has been investigated previously for calculations that use probabilities of extinction. An EDGE score (Isaac et al. 2007) simply multiplies extinction probability by ED- evolutionary distinctiveness (a score that gives each species some partial credit for ancestral branches). Naturally, that arbitrary partial credit and multiplication is not a particularly good way to determine changing expectations about the diversity that persists as the status of species changes. Faith (2008) showed how the arbitrary partial credit and multiplication in EDGE-type methods does not take phylogenetic complementarity into account, and so will not do a good job in determining conservation priorities delivering high expected PD. Faith also suggested that such priorities can be set by directly looking at expected PD gains and losses. May-Collado and Agnarsson (2011) and Kuntner et al. (2011) also concluded that the PD methods are better in achieving the goal of phylogeny-based conservation than EDGE.

These results are relevant to an interesting study by Safi et al. (2013), who set out to “identify regions of the world where priority species are concentrated, much like the original definition of the biodiversity hotspot.” They identified those regions/countries having the “highest accumulation of top mammal species ranked in terms of their EDGE score” and argued that “Conservation resources would therefore be best allocated among the countries in these regions to protect mammal species with the highest EDGE scores.”

Unfortunately, this may be a weak guideline for the efficient use of limited conservation resources. Their study recalls the issues raised by the use of ED methods in the Daru et al. study, where a given ED score could correspond either to phylogenetically clumped species and a large PD loss (as in Fig. 1, left), or phylogenetically dispersed species and smaller PD loss (Fig. 1, right). Once again, the potential PD loss arising from a given area loss is not well-indicated by a summation of ED (or EDGE values), because phylogenetic complementarity is ignored.

Recent extensions of the ED methods provide some important modifications to take into account species’ range extent and abundance; however, these interesting innovations may suffer similar problems to those described above. Cadotte et al. (2010) introduced one important extension by taking into account numbers of individuals of a given species in a community or ecosystem. The rationale, analogous to that of conventional ED, is that individuals differ in their representation of evolutionary history or phylogenetic diversity, and can receive partial “credit” for a given ancestral branch. Given that PD has been linked to ecosystem functioning (e.g. Cadotte et al. 2008, 2009), the loss of some individuals (e.g. those from species with few individuals and uniquely representing some long branches) should set off alarm

bells if we want to maintain ecosystem functions. Cadotte et al. argue that their measure “can be used by managers to identify individuals, and by extension species, whose loss corresponds to the greatest loss of evolutionary information. If, as has been proposed, evolutionary history captures functional diversity necessary for ecosystem processes and services (e.g. see Cadotte et al. 2008), minimizing this loss of evolutionary diversity might maximize the preservation of ecosystem function.”

Their basic measure, AED_i, follows the partitioning logic of ED; here, it records the share of all branches credited to any individual of species *i*. A problem is that, when AED_i values are summed over individuals, complementarity once again is ignored. This implies that the score for a set of individuals (say, those lost under a nominated management regime) cannot be a reliable indicator of potential PD loss – yet it is PD that matters, given its link to functions. We can see the problem by adapting the example of Fig. 1, imagining that the terminal branches represent individuals. The AED scores for the set of four individuals on the left (marked with B) is the same as that on the right; yet, the loss of PD feature diversity and perhaps functional diversity is much greater in the scenario on the left. Consequently, there seems to be no justification for Cadotte et al.’s claim that AED can be “used by managers to identify individuals, whose loss corresponds to the greatest loss of evolutionary information. ... minimizing this loss of evolutionary diversity might maximize the preservation of ecosystem function.” For a single individual, AED_i may be a useful index, but if a management strategy potentially impacts numerous individuals, AED will not provide a good comparative index of PD loss.

A measure similar to AED is the “biogeographically weighted evolutionary distinctiveness” metric (BED or BEDT; Cadotte and Davies 2010). BED extends ED by also partitioning the credit among (for example) the grid cells occupied by each species in a region. In this way, range extent information for species is incorporated along with phylogenetic distinctiveness. For species *i*, BED_i is a weighted sum of the ancestral branch lengths. Each length is weighted by the inverse of the sum, over all descendent species of the branch, of the number of cells occupied by the descendent species (if each descendent species is found in just one cell, then BED_i is the ED of species *i*). The BEDT score for a cell is the sum of the BED_i scores for all species *i* found in the cell. Thus, restricted range species that also uniquely represent deep branches will count a lot in the overall scores for grid cells or other areas.

As an example, in Fig. 3, suppose that we can only protect one area. Which is best? For the Area (1) in Fig. 3a, the BEDT score is BED_a + BED_b + BED_c + BED_d. The BED_i for each of these four member species (a, b, c, d) is the same, and is equal to $m/1 + L/5$. Here, the length *L* is divided by 5 because a, b, c, d, and x each are found in one area; thus, the sum of the number of cells occupied is 5. The BEDT score equals 4 times $(m/1 + L/5)$, or $4m + 4(L/5)$.

For the Area (2) in Fig. 3b, the BED_i for each of the four member species again is the same, and equal to $m/1 + L/5$. The length *L* again is divided by 5 because A and the four sister species each are found in one area. The BEDT score for Area (2) is BED_A + BED_B + BED_C + BED_D, or $4m + 4(L/5)$. BEDT therefore makes no distinction between the two areas. In contrast, the PD offered by Area (2) is much greater. Thus, BED fails to detect a huge gain in raw PD (and in restricted range PD)

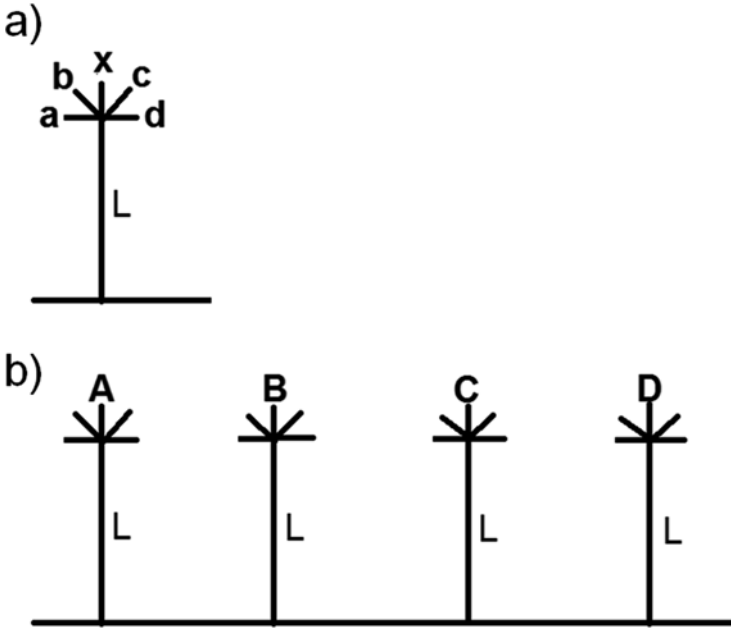

Fig. 3 Portions of hypothetical phylogenetic trees occurring in two areas. (a) Area (1) uniquely has species a , b , c , d which are on small branches of length m , and are at the end of a long branch of length L . Species x is not found in Area (1), but uniquely occurs in some other area. (b) Area (2) uniquely has species A , B , C , D , which are on small branches of length m , and are at ends of different long branches of length L . For each member species, four other sister species on small branches of length m all uniquely occur in some other area

that could be achieved through protection of the area in Fig. 3b. BED (and the related method of Tucker et al. 2012), is not effective for setting conservation priorities that reflect both phylogenetic diversity and range-restrictedness. I conclude that there is little justification for Cadotte et al.'s conclusion that "Metrics such as BEDT, which combines evolutionary diversity and rarity into a single measure of diversity, may allow a more holistic approach to conservation prioritization."

I noted above that PD gives priority to Area 2 in Fig. 3b, because it offers almost 4 times as much PD. However, this basic PD calculation does not take range rarity into account. Weighted PD-endemism or "PE" (the sum of branches represented in an area, each inverse-weighted by its range, expressed as number of cells; Rosauer et al. 2009) also gives priority to Area 2, because it scores Area 1 with a PE score of $4m + L/2$, and Area 2 with a higher PE score of $4m + 4(L/2)$.

PE has an interesting property analogous to ED, in that a given cell receives proportional credit for a branch (analogous to the basic ED score where a species gets proportional credit for branches). PE performs well in the example above; however, it shares a weakness of ED, when combined with probabilities and summed-up to provide overall scores. To see this, I consider a recent study of the phylogeny of Malagasy lemuriformes (Gudde et al. 2013). This study set out to identify places

with a concentration of threatened phylogenetic distinctive and rare species. Here, the PE measure was combined with probabilities of extinction. Their “imperilled phylogenetic endemism” (IPE) index is the sum over all branches of branch length times its probability of extinction (product of extinction probabilities of all descendants) times the inverse of its range-extent.

Gudde et al. (2013) claimed to “quantify where on the landscape at-risk evolutionary history is concentrated.” However, their “imperilled phylogenetic endemism” (IPE) index appears to have the weakness that it could highlight places that have no threatened branches at all. As a revealing example, suppose that area A has 20 species, all of IUCN “least concern” (see IUCN 2006, 2012). Suppose that this corresponds to a low probability of extinction of 0.025 (for methods and discussion, see Mooers et al. 2008; Faith and Richards 2012). Each species is found in only ten areas. Suppose that area B has five species, all IUCN “critically endangered” (probability of extinction assumed to be a higher 0.4). Each species is found in 50 areas, but all are found together in this one area. Suppose also that each species is at the end of a branch of some unit length. Also, for simplicity, I will ignore deeper branches (assuming that all species have numerous secure sisters).

IPE in this simple case is equal to the product of the number of branches, the probability of extinction and the inverse of the number of cells containing a given branch. Application of IPE gives area A the higher priority; the IPE score equals 20 times 0.025 times 1/10 or 0.05. IPE gives area B the lower priority; the IPE score equals 5 times 0.4 times 1/50 or 0.04. Application of IPE therefore would ignore the opportunity to save, with a reserve based around area B, five critically endangered species. Instead, IPE would give preference to an area with 20 non-threatened species! This reveals the key limitation of the approach. IPE is supposed to reflect a concentration of range restricted, threatened species. Gudde et al. (2013) argued that “our mapping does indeed quantify where at risk PD is concentrated”. However, IPE, in the example above, actually quantified where *not-at-risk* PD was concentrated!

This weakness of IPE is similar to that of EDGE (see above and Faith 2008). Both methods suffer the weakness that phylogenetic overlap of species is not effectively taken into account. For EDGE type assessments, an existing probabilistic PD approach (Witting and Loeschcke 1995) performs better (Faith 2008; see also May-Collado and Agnarsson 2011; Kuntner et al. 2011). In the final section, I examine the prospects for using this “expected PD” approach to address some conservation assessment problems that have been unsuccessfully treated by the ED type methods.

The PE measure is relevant to another study that attempts to integrate range extent and threat information into PD assessments. In their global study on conservation of phylogenetic diversity of birds, Jetz et al. (2014) devised a measure related to ED to provide scores for regions or areas. Their “EDR” score for a species is simply the ED value divided by the range (number of occupied cells) of the species. Total EDR for a given region then is the summed EDR of all species occurring in the region. Jetz et al. ask, “Under an objective of minimizing global PD loss, how do ED and EDR perform as metrics for a rule-based approach to taxon- and

area-based conservation priority setting?” They claim that EDR indicates high priority conservation areas. However, this modified ED score, when summed to produce EDR area scores, again will not reflect PD (Fig. 2), nor amount of PD that would be lost (Fig. 1).

An alternative, incorporating range information, is a modification of PE.

A threatened-PE (TPE) area score only counts up threatened branches (e.g. those having only threatened descendents; see also Faith 2015). If the range-extents of many species are declining, TPE may be an effective simple index to monitor over time. The TPE of an area will increase if more of its species/branches are threatened or if range extent decreases for some of its species.

Prospects

In the examples presented above, assessments of sets of taxa (and/or areas) focussed on two related goals. One was the assessment of losses in PD (as in Fig. 1) and the other was assessment of gains in PD (as in Fig. 2). Regarding gains, it is apparent that some indices may fail to record a large gain in PD, because they do not detect the degree to which a set of taxa is spread out phylogenetically. Regarding losses, some indices may miss a large loss in PD because they do not take into account the fact that a set of taxa are clumped phylogenetically. The latter case is a particularly important one, given that these scenarios may correspond to “phylogenetic tipping points”, where long, deeper, branches of the phylogeny are lost (see Faith et al. 2010; Faith and Richards 2012),

The theme of PD gains and losses is a critical one also for the conservation assessment of geographic areas. For species/taxon priorities, the expected PD methods have advantages over the ED and EDGE approaches for estimating expected gains or expected losses (Faith 2008). The application of expected PD by Jono and Pavoine (2012), noted above, provided an example of such an effective assessment of PD expected gains or losses. We also need effective estimates of the expected PD gains or expected PD losses for entire areas or regions.

Expected PD will have advantages over other methods for assessments of areas. For example, the study of Safi et al. (2013), discussed above, highlighted the importance of identifying regions having a concentration of threatened species and phylogenetic diversity. However, they focussed on the “highest accumulation of top mammal species ranked in terms of their EDGE score.” Similarly, Gudde et al. (2013) set out to identify places with a concentration of threatened phylogenetically distinctive and rare species. Both studies, while identifying important assessment issues for the future, unfortunately applied methods that do not fully integrate the principle of phylogenetic complementarity. The expected PD framework may provide an effective way to address such assessment goals.

The identification of Key Biodiversity Areas (KBAs) is one important context for future work of this kind. KBAs are defined as sites of global significance for biodiversity conservation: “contributing significantly to the global persistence of

biodiversity” (see http://www.iucn.org/about/work/programmes/gpap_home/gpap_biodiversity/gpap_wcpabiodiv/gpap_pabiodiv/key_biodiversity_areas/; Foster et al. 2012). KBAs typically are identified based on the presence of globally threatened (and/or geographically restricted) species. However, a gap exists in defining and identifying KBAs at the genetic and phylogenetic levels. Expected PD calculations could fill this gap in providing information about both expected gains and expected losses.

As an example, we could examine the gain in expected PD, if a given KBA were protected (probabilities of extinction transformed to some small value). This would be useful in revealing a concentration of threatened PD. On the other hand, we could examine the loss in expected PD if the area was lost (received no protection). This would be useful, in contrast to the IPE measure of Gudde et al. (2013), in revealing areas that have geographically restricted elements of threatened PD. Future work may examine how these basic calculations of expected gains and losses can be used in combination to defined priorities for KBAs and other geographic areas as conservation foci.

Open Access This chapter is distributed under the terms of the Creative Commons Attribution-Noncommercial 2.5 License (<http://creativecommons.org/licenses/by-nc/2.5/>) which permits any noncommercial use, distribution, and reproduction in any medium, provided the original author(s) and source are credited.

The images or other third party material in this chapter are included in the work’s Creative Commons license, unless indicated otherwise in the credit line; if such material is not included in the work’s Creative Commons license and the respective action is not permitted by statutory regulation, users will need to obtain permission from the license holder to duplicate, adapt or reproduce the material.

References

- Abellán P, Sánchez-Fernández D, Picazo F, Millán A, Lobo JM, Riber I (2013) Preserving the evolutionary history of freshwater biota in Iberian. *Natl Parks Biol Conserv* 162:116–126
- Bordewich M, Semple C (2012) Budgeted nature reserve selection with biodiversity feature loss and arbitrary split systems. *J Math Biol* 64:69–85
- Cadotte MW, Cardinale BJ, Oakley TH (2008) Evolutionary history and the effect of biodiversity on plant productivity. *Proc Natl Acad Sci U S A* 105(44):17012–17017
- Cadotte MW, Cavender-Bares J, Tilman D, Oakley TH (2009) Using phylogenetic, functional and trait diversity to understand patterns of plant community productivity. *PLoS One* 4(5):e5695
- Cadotte MW, Davies TJ (2010) Rarest of the rare: advances in combining evolutionary distinctiveness and scarcity to inform conservation at biogeographical scales. *Divers Distrib* 16:376–385
- Cadotte MW, Davies TJ, Regetz J, Kembel SW, Cleland EE, Oakley TH (2010) Phylogenetic diversity metrics for ecological communities: integrating species richness, abundance and evolutionary history. *Ecol Lett* 13:96–105
- Chao A, Chiu C-H, Jost L (2010) Phylogenetic diversity measures based on Hill numbers. *Philos Trans R Soc B* 365:3599–3609

- Collen B, Turvey ST, Waterman C et al (2011) Investing in evolutionary history: implementing a phylogenetic approach for mammal conservation. *R Soc Philos Trans Biol Sci* 366:2611–2622
- Dalerum F (2013) Phylogenetic and functional diversity in large carnivore assemblages. *Proc R Soc B* 280:20130049
- Daru BH, Yessoufou K, Mankga LT, Davies TJ (2013) A global trend towards the loss of evolutionarily unique species in mangrove ecosystems. *PLoS One* 8(6):e66686
- Davies TJ, Buckley LB (2011) Phylogenetic diversity as a window into the evolutionary and biogeographic histories of present-day richness gradients for mammals. *Philos Trans R Soc B* 366:2414–2425
- Devictor V, Mouillot D, Meynard C, Jiguet F, Thuiller W, Mouquet N (2010) Spatial mismatch and congruence between taxonomic, phylogenetic and functional diversity: the need for integrative conservation strategies in a changing world. *Ecol Lett* 13:1030–1040
- Diniz-Filho JA, Loyola RD, Raia P, Mooers AO, Bini LM (2013) Darwinian shortfalls in biodiversity conservation. *Trends Ecol Evol* 28:689–695
- Faith DP (1992a) Conservation evaluation and phylogenetic diversity. *Biol Conserv* 61:1–10
- Faith DP (1992b) Systematics and conservation: on predicting the feature diversity of subsets of taxa. *Cladistics* 8:361–373
- Faith DP (1994a) Phylogenetic pattern and the quantification of organismal biodiversity. *Philos Trans R Soc B* 345:45–58
- Faith DP (1994b) Phylogenetic diversity: a general framework for the prediction of feature diversity. In: Forey PL, Humphries CJ, Vane-Wright RI (eds) *Systematics and conservation evaluation*. Clarendon, Oxford, pp 251–268
- Faith DP (1996) Conservation priorities and phylogenetic pattern. *Conserv Biol* 10:1286–1289
- Faith DP (2008) Threatened species and the preservation of phylogenetic diversity (PD): assessments based on extinction probabilities and risk analysis. *Conserv Biol* 22:1461–1470
- Faith DP (2013) Biodiversity and evolutionary history: useful extensions of the PD phylogenetic diversity assessment framework. *Ann N Y Acad Sci* 1289:69–89
- Faith DP (2015) Phylogenetic diversity and extinction: avoiding tipping points and worst-case losses from the tree of life. *Proc R Soc Lond B* 370:20140011.
- Faith DP, Richards ZT (2012) Implications of climate change for the tree of life. *Biology* 1:906–932
- Faith DP et al (2004) Integrating phylogenetic diversity, complementarity, and endemism for conservation assessment. *Conserv Biol* 18:255–261
- Faith DP et al (2009) The cladistic basis for the Phylogenetic Diversity (PD) measure links evolutionary features to environmental gradients and supports broad applications of microbial ecology's "phylogenetic beta diversity" framework. *Int J Mol Sci* 10:4723–4741
- Faith DP, Magallón S, Hendry AP, Conti E, Yahara T, Donoghue MJ (2010) Ecosystem services: an evolutionary perspective on the links between biodiversity and human-well-being. *Curr Opin Environ Sustain* 2:66–74
- Forest F et al (2007) Preserving the evolutionary potential of floras in biodiversity hotspots. *Nature* 445:757–760
- Foster MN, Brooks TM, Cuttelod A, de Silva N, Fishpool LDC, Radford EA, Woodley S (2012) The identification of sites of biodiversity conservation significance: progress with the application of a global standard. *J Threatened Taxa* 4:2733–2744
- Gotelli NJ, Chao A (2013) Measuring and estimating species richness, species diversity, and biotic similarity from sampling data. In: Levin SA (ed) *Encyclopedia of biodiversity*, vol 5, 2nd edn. Academic, Waltham, pp 195–211
- Gravel D et al (2012) Phylogenetic constraints on ecosystem functioning. *Nat Commun* 3:1117
- Gudde RM, Joy JB, Mooers AO (2013) Imperilled phylogenetic endemism of Malagasy lemuri-formes. *Divers Distrib* 19:1–12
- Huang S et al (2012) Traits, trees and taxa: global dimensions of biodiversity in mammals. *Proc R Soc B* 279:4997–5003

- Isaac NJB et al (2007) Mammals on the EDGE: conservation priorities based on threat and phylogeny. *PLoS One* 2:e296
- IUCN (1980) World conservation strategy: living resource conservation for sustainable development. International Union for Conservation of Nature and Natural Resources (IUCN), Gland, Switzerland.
- IUCN Red List Standards and Petitions Subcommittee (2006) Guidelines for using the IUCN red list categories and criteria. IUCN, Gland, Switzerland. Available from <http://www.iucn.org/webfiles/doc/SSC/RedList/RedListGuidelines.pdf>
- IUCN (2012) IUCN red list of threatened species. Available: <http://www.redlist.org>
- Jetz W et al (2014) Global distribution and conservation of evolutionary distinctness in birds. *Curr Biol* 24:919–930
- Jono CMA, Pavoine S (2012) Threat diversity will erode mammalian phylogenetic diversity in the near future. *PLoS One* 7(9), e46235. doi:10.1371/journal.pone.0046235
- Kelly S, Grenyer R, Scotland RW (2014) Phylogenetic trees do not reliably predict feature diversity. *Divers Distrib* 20:600–612
- Kuntner M, May-Collado LJ, Agnarsson I (2011) Phylogeny and conservation priorities of afrotherian mammals (Afrotheria, Mammalia). *Zool Scr* 40:1–15
- Larsen FW, Turner WR, Brooks TM et al (2012) Conserving critical sites for biodiversity provides disproportionate benefits to people. *PLoS One* 7, e36971
- López-Orsorio F, Miranda-Esquivel DR (2010) A phylogenetic approach to conserving Amazonian biodiversity. *Conserv Biol* 24:1359–1366
- Lozupone C, Knight R (2005) UniFrac: a new phylogenetic method for comparing microbial communities. *Appl Environ Microbiol* 71:8228–8235
- Maclaurin J, Sterelny K (2008) What is biodiversity? The University of Chicago Press, Chicago
- May-Collado LJ, Agnarsson I (2011) Phylogenetic analysis of conservation priorities for aquatic mammals and their terrestrial relatives, with a comparison of methods. *PLoS One* 6(7), e22562. doi:10.1371/journal.pone.0022562
- McNeely JA (1988) Economics and biological diversity: developing and using economic incentives to conserve biological resources. IUCN, Gland, Switzerland, 232 pp
- McNeely JA, Miller KR, Reid WV, Mittermeier RA, Werner TB (1990) Conserving the World's biological diversity. International Union for Conservation of Nature and Natural Resources/World Resources Institute/Conservation International/World Wildlife Fund/US World Bank, Gland
- McNeely JA et al (2005) Biodiversity. In: Chopra K et al (eds) Ecosystems and human well-being, vol 3, Policy responses. Millennium Ecosystem Assessment, Island Press, Washington, DC, pp 119–172
- Millennium Ecosystem Assessment (2005) Ecosystems and human well-being: biodiversity synthesis. World Resources Institute, Washington, DC
- Mooers AØ, Atkins R (2003) Indonesia's threatened birds: over 500 million years of evolutionary heritage at risk. *Anim Conserv* 6:183–188
- Mooers AO et al (2008) Converting endangered species categories to probabilities of extinction for phylogenetic conservation prioritization. *PLoS One* 3, e3700. doi:10.1371/journal.pone.0003700
- Morgan GJ (2010) Evaluating Maclaurin and Sterelny's conception of biodiversity in cases of frequent, promiscuous lateral gene transfer. *Biol Philos* 25:603–621
- Pacharawongsakda E, Yokwai S, Ingsriswang S (2009) Potential natural product discovery from microbes through a diversity-guided computational framework. *Appl Microbiol Biotechnol* 82:579–586
- Perez-Losada M, Jara CG, Bond-Buckup G, Crandall KA (2002) Conservation phylogenetics of Chilean freshwater crabs *Aegla* (Anomura, Aeglidae): assigning priorities for aquatic habitat protection. *Biol Conserv* 105:345–353
- Pio DV et al (2014) Climate change effects on animal and plant phylogenetic diversity in southern Africa. *Glob Chang Biol* 20:1538–1549

- Posadas P, Miranda Esquivel DR, Crisci JV (2001) Using phylogenetic diversity measures to set priorities in conservation: an example from Southern South America. *Conserv Biol* 15:1325–1334
- Reid WV, Miller K (1989) Keeping options alive: the scientific basis for conserving biodiversity. World Resources Institute, Washington, DC, 1989 – Science – 128 pp
- Rosauer D, Laffan SW, Crisp MD, Donnellan SC, Cool LG (2009) Phylogenetic endemism: a new approach for identifying geographical concentrations of evolutionary history. *Mol Ecol* 18:4061–4072
- Safi K, Armour-Marshall K, Baillie JEM, Isaac NJB (2013) Global patterns of evolutionary distinct and globally endangered amphibians and mammals. *PLoS One* 8(5), e63582
- Sarkar S (2008) From ecological diversity to biodiversity. In: Hull D, Ruse M (eds) *The Cambridge companion to the philosophy of biology*. Cambridge University Press, Cambridge
- Saslis-Lagoudakisa CH, Savolainen V, Williamson EM, Forest F, Wagstaff SJ, Baral SR, Watson MF, Pendry CA et al (2012) Phylogenies reveal predictive power of traditional medicine in bioprospecting. *Proc Natl Acad Sci* 109:15835–15840
- Soulé ME (1980) *Conservation biology: an evolutionary-ecological perspective*. Sinauer Associates, Sunderland, 395 pp
- Smith WL, Wheeler WC (2006) Venom evolution widespread in fishes: a phylogenetic road map for the bioprospecting of piscine venoms. *J Hered* 97:206–217
- Tucker CM, Cadotte MW, Davies TJ, Rebelo AG (2012) The distribution of biodiversity: linking richness to geographical and evolutionary rarity in a biodiversity hotspot. *Conserv Biol* 26:593–601
- UNEP (2013) Report of the second session of the Plenary of the Intergovernmental Science-Policy Platform on Biodiversity and Ecosystem Services. IPBES/2/17, Nairobi, Kenya.
- Vamosi JC, Wilson JR (2008) Nonrandom extinction leads to elevated loss of angiosperm evolutionary history. *Ecol Lett* 11:1047–1053
- Vane-Wright RI, Humphries CJ, Williams PH (1991) What to protect—systematics and the agony of choice. *Biol Conserv* 55:235–254
- Weikard H (2002) Diversity functions and the value of biodiversity. *Land Econ* 78:20–27
- Weitzman ML (1992) On diversity. *Q J Econ* 107:363–405
- Wilson EO (1992) *The diversity of life*. Norton, New York
- Winter M, Devictor V, Schweiger O (2013) Phylogenetic diversity and nature conservation: where are we? *Trends Ecol Evol* 28:199–204
- Witting L, Loeschcke V (1995) The optimization of biodiversity conservation. *Biol Conserv* 71:205–207